

# Thomson Electrak<sup>®</sup> LL Electric Linear Actuator

Installation Manual

Edition 2026-01



## Version history

<b>Edition</b>	<b>Reason for revision</b>
2020-04	First edition
2020-11	Page references added after brake resistor in diagram legend + back page updated
2021-08	Updated warning for onboard control signals (control type LEX)
2022-05	Date added to the CE declaration
2023-08	Update 2012-08 was lost during 2022-05 update and now added again
2023-09	Page headers and section numbering corrected
2024-06	New controls, new supply voltage and a higher speed version added
2024-08	Updated the available current range over CAN
2025-03	Updates to the Control Option Specifications tables
2025-07	LXP: Corrected lead numbering of supply voltage for position feedback
2026-01	Updated front and back cover logotypes and layout

## Warranty

The Thomson Electrak® LL is warranted to be free from defects in materials and workmanship for a period of twelve (12) months from date of delivery. The application of this product is the responsibility of the buyer and Thomson makes no representation or warranty as to the suitability of the product for any particular use or purpose. For a copy of the entire warranty for this product that is contained in our standard terms and conditions of sale, please go to [http://www.thomsonlinear.com/website/com/eng/support/terms\\_and\\_conditions.php](http://www.thomsonlinear.com/website/com/eng/support/terms_and_conditions.php).

## Disclaimer

**Technical changes to improve the performance of the equipment may be made without prior notice!**

All rights reserved. No part of this work may be reproduced in any form (by printing, photocopying, microfilm or any other method) or processed, copied or distributed by electronic means without the written permission of Thomson.

Contents

<b>1. General</b> .....	<b>4</b>
1.1 About this manual .....	4
1.2 Target group .....	4
1.3 Symbols used .....	4
1.4 Transport and storage .....	4
1.5 Packaging .....	4
1.6 Disposal .....	4
1.7 Support .....	4
<b>2. Safety</b> .....	<b>5</b>
2.1 Safety notes .....	5
<b>3. Standards</b> .....	<b>6</b>
3.1 EC Declaration of conformity .....	6
<b>4. Installation</b> .....	<b>7</b>
4.1 Product label .....	7
4.2 Terminology .....	7
4.3 Operation environment .....	7
4.4 Mechanical installation .....	8
4.5 Electrical installation .....	11
4.6 Control options installation and operation .....	13
<b>5. CAN bus SAE J1939 information</b> .....	<b>20</b>
5.1 Introduction to CAN bus SAE J1939 .....	20
5.2 CAN bus SAE J1939 communications protocol .....	20
<b>6. CAN bus CANopen information</b> .....	<b>24</b>
6.1 Introduction to CAN bus CANopen .....	24
6.2 Actuator control .....	24
6.4 Actuator feedback .....	26
<b>7. Troubleshooting</b> .....	<b>28</b>
7.1 Troubleshooting .....	28
<b>8. Technical specifications</b> .....	<b>29</b>
8.1 Technical data .....	29
8.2 Ordering key .....	30

## 1. General

### 1.1 About this manual

This manual contains mechanical and electrical installation instructions for the Thomson Electrak® LL electric linear actuator. It also contains, among other things:

- technical data
- installation data
- type designation key.

It is important to carefully read this manual before installing the actuator and to have the correct qualifications needed to perform the installation.

### 1.2 Target group

This manual addresses qualified mechanical and electrical personnel.

### 1.3 Symbols used



This symbol is shown to highlight a general warning, general instruction or as a warning for a mechanical hazard.

### 1.4 Transport and storage

The actuator may only be transported and stored in the original packaging supplied by Thomson. The temperature during transportation and storage must be between -40 to +85° C (-40 to +185° F). Avoid shocks to the package. If the package is damaged, check the actuator for visible damage and notify the carrier, and if appropriate also Thomson.

### 1.5 Packaging

The packaging consists of a cardboard box. The box contains the actuator and this manual. For large quantity orders bulk packaging may be used in which case the packaging and the content will vary depending on the order agreement.

### 1.6 Disposal

Where required by law, used packaging and actuators are taken back by Thomson for professional disposal if the transportation cost is paid by the sender. Please contact Thomson for shipping information.

### 1.7 Support

If technical support or information is needed for this product, please contact the nearest Thomson Service Center. See the back of this manual. You can also visit [www.thomsonlinear.com](http://www.thomsonlinear.com) for information on this product and how to contact us.

## 2. Safety

### 2.1 Safety notes



- Only properly qualified personnel are permitted to perform mechanical and electrical installation of this product. Properly qualified personnel are familiar with mechanical or electrical installation work and have the appropriate qualifications for their job.
- Read this manual and any other available documentation before working on the equipment that the actuator is or shall be a part of.
- Conform strictly to the information contained in this manual and on the actuator product label on the actuator. Never exceed the performance limits stated herein.
- Never work on the actuator or its installation with the power on.
- Never unplug any cables or connectors during operation or with power on.
- Immediately stop using the actuator if it seems faulty or damaged in any way and notify an appropriate person so that corrective actions can be taken.
- Never open the actuator as that will compromise the sealing and the function of the actuator. There are no serviceable components inside.
- Grease may be present on the extension tube. Contact is non-hazardous. Film should not be removed.

### 3. Standards

#### 3.1 EC Declaration of incorporation of partly completed machinery

## CE Declaration of Conformity of partially completed machinery



#### We, the company

Tollo Linear AB, Bredbandsvägen 12, 291 62 Kristianstad, Sweden

#### Hereby in sole responsibility declare the conformity of the product series

Electric Linear Actuator Electrak LL  
(all model types included)

#### Manufactured by

Tollo Linear AB, Bredbandsvägen 12, 291 62 Kristianstad, Sweden

#### With the following directive

- EC-Directive 2006/42/EC – Machine Directive (MD)

Used Harmonized Standard(s):  
EN ISO 12100:2010 – Safety of Machinery – General Principles for Design - Risk Assessment and Risk Reduction

#### And further directive(s)

- EC-Directive 2014/30/EU – Electromagnetic Compatibility Directive (EMCD)  
Used Harmonized Standard(s):  
EN 12895:2015+A1:2019 – Electromagnetic compatibility (EMC) – Industrial Trucks  
IEC 61000-4-3:2020 - Electromagnetic compatibility (EMC) - Testing and measurement techniques - Radiated electromagnetic field immunity test - 27 to 1000MHz at 10V/m, 1000 to 6000MHz at 3V/m performance criteria A  
IEC 61000-4-3:2020 - Electromagnetic compatibility (EMC) - Testing and measurement techniques - Radiated electromagnetic field immunity test - 27 to 1000MHz at 20V/m performance criteria B
- EC-Directive 2011/65/EU with amendment 2015/863/EU – Restriction of Hazardous Substances in Electrical and Electronic Equipment (RoHS2 & RoHS3)
- EC-Directive 2012/19/EU – Waste Electrical and Electronic Equipment (WEEE)

**Year of first Declaration:** 2024

Safety depends upon installing and configuring the linear actuator per the manufacturer's recommendations. The machine in which this product is to be installed must conform to the provisions of the EMC directive 2014/30/EU. The installer is responsible for ensuring that the end product complies with the EMI requirements and all the relevant laws in the country where the equipment is installed.

**Issued by:** Product Line Manager  
Mr. Håkan Persson  
Kristianstad, 2024-07-10

  
Signature

#### Responsible person for technical documentation:

Mr. Peter Gnebnér, Tollo Linear AB, Bredbandsvägen 12, 291 62 Kristianstad, Sweden

Doc. No: 110916

Tollo Linear AB • Bredbandsvägen 12, 291 62 Kristianstad • Sweden • T +46(0)44-5902400  
Tollo Linear AB • Box 9053 • SE-291 09 Kristianstad • Sweden • www.thomsonlinear.com

## 4. Installation

### 4.1 Product label

The product label can be found on the side of the cover tube. It will tell you which model of actuator you have, its basic performance data and where it is manufactured. Please study the product label to determine actuator type before starting any installation or service on the actuator. If you need any assistance from Thomson, please provide the serial number, manufacturing date and the designation of the actuator(s) in question. You can also use the QR code on the label to directly access Electrak LL information on [www.thomsonlinear.com](http://www.thomsonlinear.com).

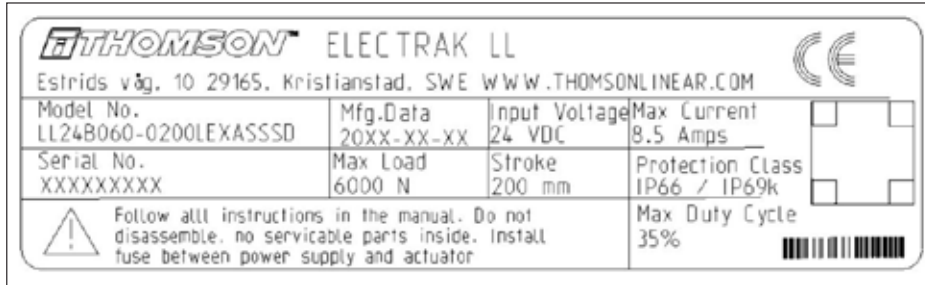

### 4.2 Terminology

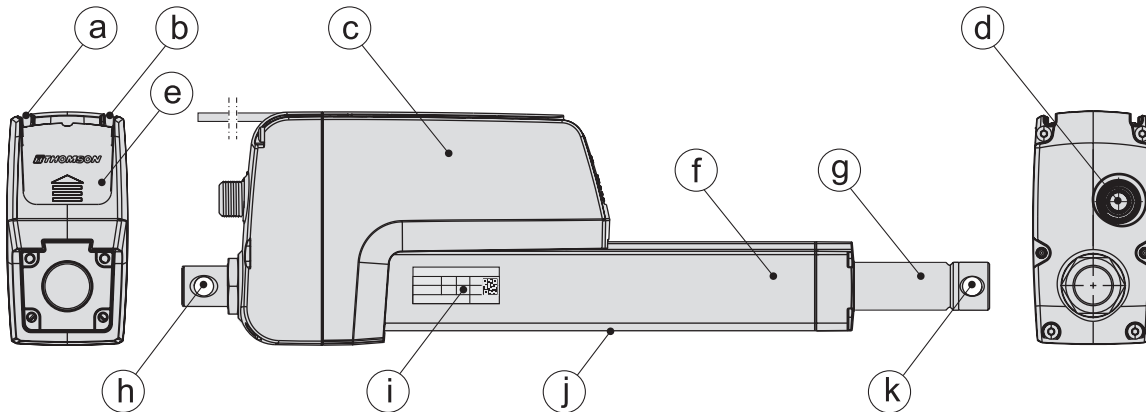

- a. power cable
- b. signal cable
- c. housing
- d. hand wind input
- e. cable connector cover plate
- f. cover tube
- g. extension tube
- h. rear adapter
- i. product label
- j. limit switch slots
- k. front adapter

### 4.3 Operation environment



**Min. -40° C (-40° F)**



**Max. +85° C (+185° F)**



**IP66 / IP69K**

1. Operation temperature range is -40 to +85° Celsius (-40 to +185° Fahrenheit).
2. Protection degree against the ingress of water and particles is IP66 / IP69K.
3. Relative humidity range is 10 - 90 % non-condensing.

### 4.4 Mechanical installation

#### 4.4.1 General installation safety notes



- Never work on the actuator with the power switched on!
- Do not hold the extension tube while the unit is energized.
- Failure modes of the actuator should be considered to ensure it does not create harm.

#### 4.4.2 Basic installation considerations

1. Only mount the actuator using the holes in the rear (a) and front (b) adapters. Check the model number on the actuator product label (section 4.1) and then look at the ordering key (section 7.2) to find out your adapter type configuration. See the below drawings and table to find out the exact adapter dimensions.
2. Make sure that the actuator mounting position allows access to the cable connector cover plate (c), so that it can be removed to allow access to the cable connector(s) (section 4.4.4).
3. The cable or cables (d) exit the cable slot at the rear of the actuator housing at delivery but can be made to leave the housing at any point after the cable connector cover plate.
4. The hand wind input (e) must have enough free space around it to allow it to be operated (section 4.4.5).
5. If external limit switches will be used, the mounting of the actuator must allow access to the limit switch slots (f) running along the underside of the cover tube (section 4.4.6).

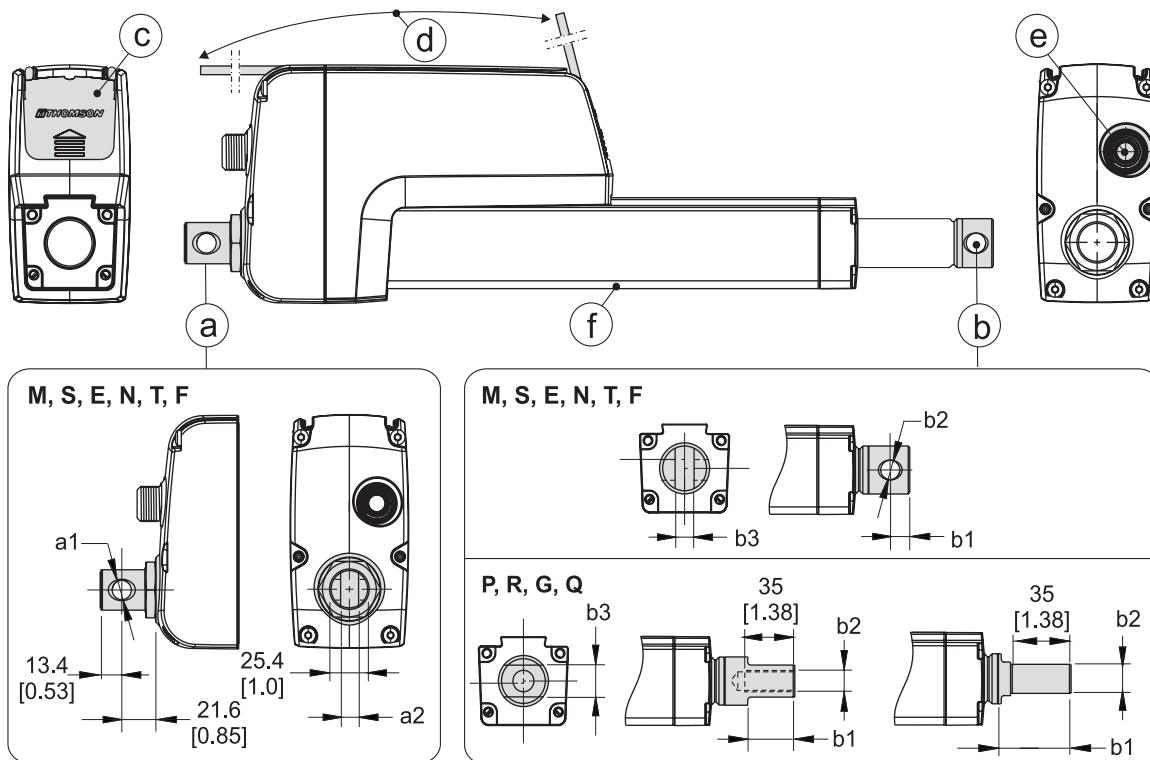

Adapter Dimensions [mm (in)]							
Adapter type							
	M, S	E	N, T	F	P, R	G	Q
a1	12.2 E9 (0.48)	12.8 (0.506)	12.2 E9 (0.48)	12.8 (0.506)	-	-	-
a2	-	-	8.2 (0.323)	8.2 (0.323)	-	-	-
b1	10.9 (0.429)	10.9 (0.429)	12.9 (0.508)	12.9 (0.508)	30 (1.18)	30 (1.18)	42 (1.654)
b2	12.2 E9 (0.48)	12.8 (0.506)	12.2 E9 (0.48)	12.8 (0.506)	M12 × 1.75	1/2-20 NF-2B	M16 × 2
b3	-	-	8.2 (0.323)	8.2 (0.323)	19 (0.748)	19 (0.748)	19 (0.748)

**4.4.3 Mounting orientation and forces**

1. The actuator can be mounted in any orientation and handle both pushing and pulling loads.
2. Always install actuator so that the force of the load acts in the center of the extension tube and the rear adapter.
3. Only mount the actuator to the rear and front adapter mounting holes.
4. Only use solid mounting pins and support them at both ends.
5. The mounting pins must be parallel to each other both radially and axially.

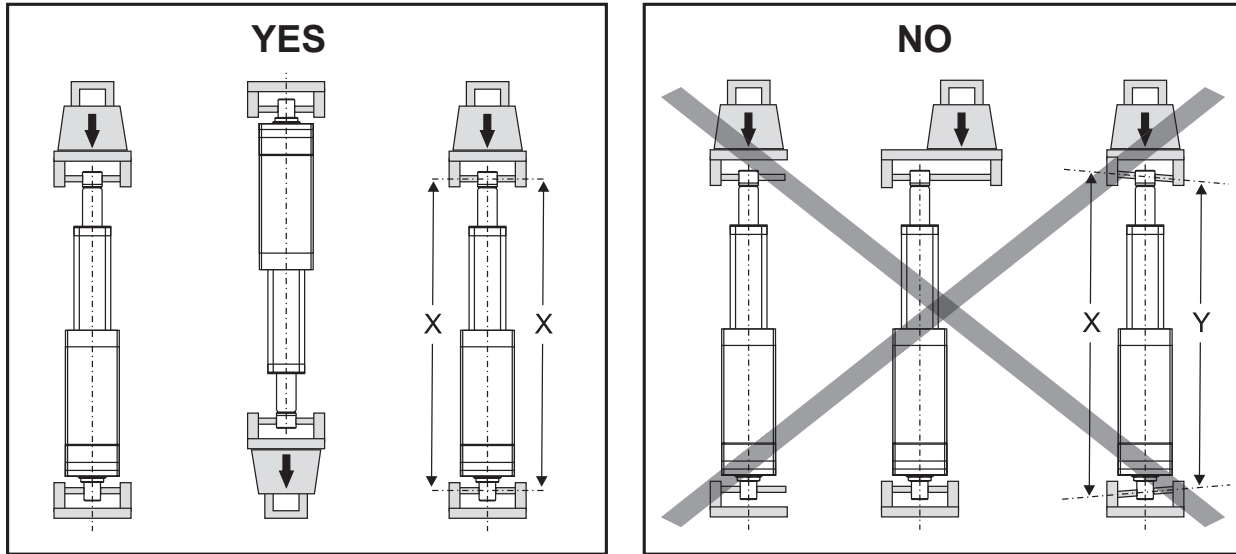

**4.4.4 Cable connector cover plate**

1. The cover plate is held in place by a screw (M3 with Torx T10 head) that can be accessed through the hole in the top of the cover plate (a). Keep in mind to mount the actuator so that there is enough clearance to access the screw with a tool!
2. Once the cover plate is released it needs to be pushed about 20 mm (0.8 inch) in the direction of the arrow symbol on the cover plate before it can be removed from the actuator (b). The connectors are a part of the backside of the cover plate and can be accessed once the cover plate is removed.
3. Make sure to put the cover plate back correctly and torque the screw to 1.2Nm (10.6 in-lb) to ensure that the actuator cover plate and connectors are properly sealed.

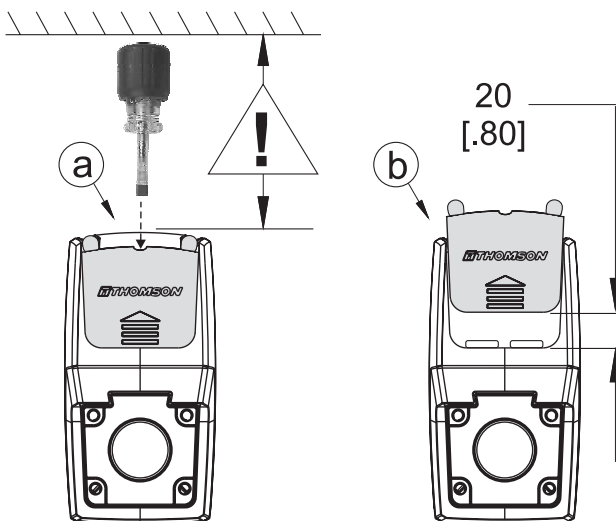

**4.4.5 Hand wind mounting and operation**

1. Make sure when mounting the actuator that there is space enough between the rear adapter and any object behind it to allow the hand wind to be operated!
2. To be able to operate the hand wind, remove the cover plug placed over the hand wind input (a).
3. Next, move the extension tube by turning the hand wind input hexagon socket (b) using a 6 mm male hexagon key (c).
4. The maximum torque required to move the extension tube at the fully rated actuator load using the hand wind is typically 4-6 Nm (35-50 in-lb).

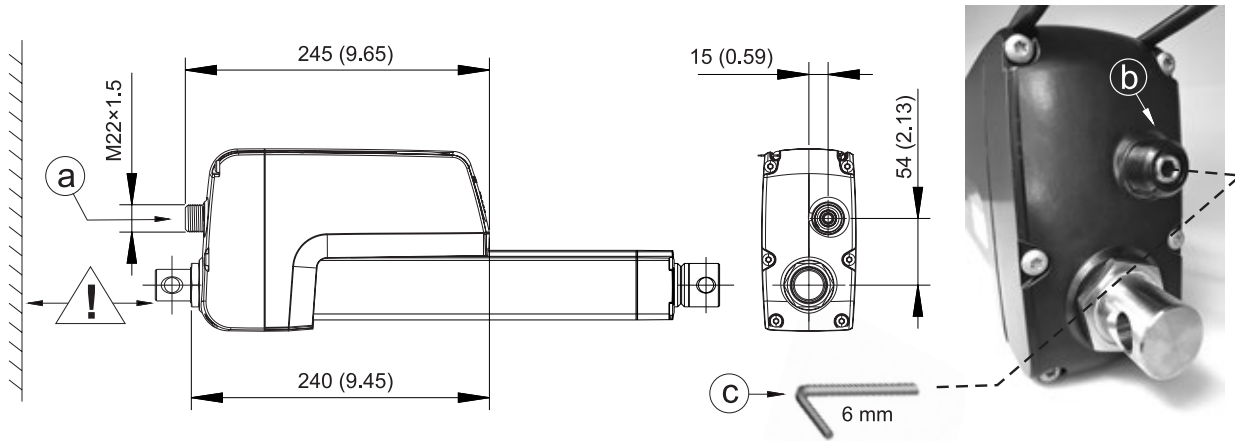

Always make sure to switch off the power to the actuator before using the hand wind. Do not apply higher torque than 10 Nm (88 in-lb) to the hand wind input. Never run the extension tube in to the end of stroke as that may damage the actuator. Never use any type of drill or power tool to operate the hand wind.

**4.4.6 Mounting of optional external limit switches**

1. The external limit switches are mounted in the two slots (a) at the bottom of the cover tube.
2. Put the sensor (b) into one of the slots and and lock it at the desired position by turning the clamp screw 45 degrees (c).

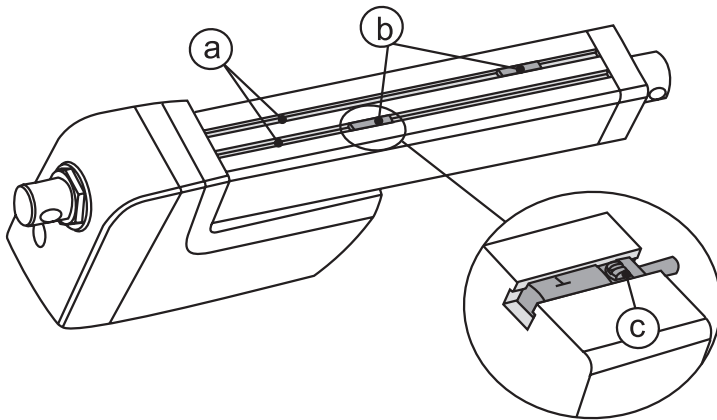

If the sensor is mounted in the immediate vicinity of magnetic components, the switching characteristics of the sensor may change.

### 4.5 Electrical installation

#### 4.5.1 General notes



- Make sure the leads/cables leading to the motor can handle the maximum motor current.
- An emergency stop is recommended to reduce the chance of a crushing hazard.
- Never work on the actuator or the wiring with the power switched on!

#### 4.5.2 Fuse size

Protect the actuator and the wiring by using a slow blow fuse between the actuator and the power source.

Recommended Fuse Size	
Actuator supply voltage	Fuse size
24 Vdc	20 A
48 Vdc	10 A

#### 4.5.3 Electrical connections

The actuator is supplied with a power cable (a) and a signal cable (b). The cable(s) have flying leads in one end for customer connections. In the other end the cable(s) are integrated in to the cable connector cover plate (c) (section 4.4.4). The plug in connector allows replacing the actuator without disconnecting the flying leads. The leads in the cables can be marked with numbers or colors depending on the type of cable option selected.

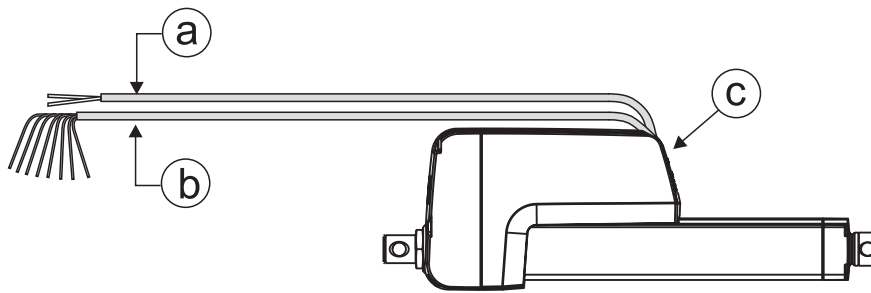

#### 4.5.4 Lead cross sections

To avoid malfunction due to voltage drop the cross section of the leads between the actuator power cable leads and the power source must be of sufficient size. For longer cables than stated in the table, calculations based on the supply voltage, the current draw, the length of the cables and the ambient temperature must be done.

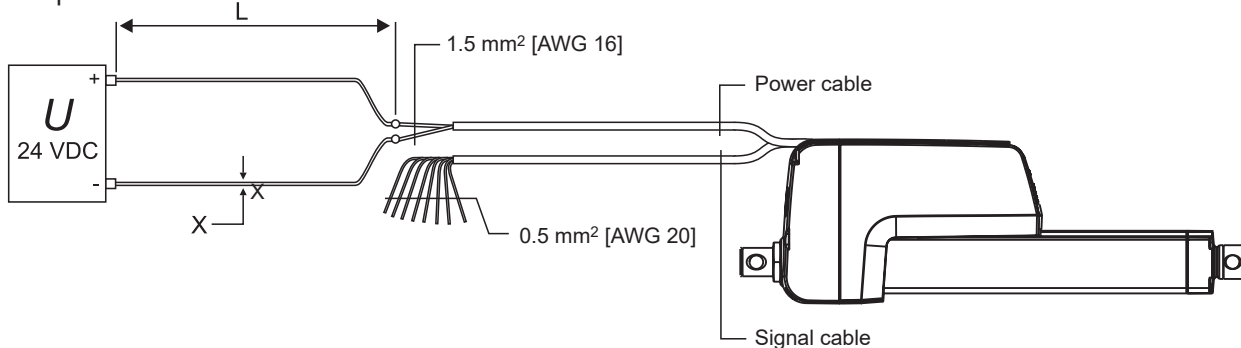

Power Lead Cross Sections	
Length of cable (L)	Min. allowed cross section (X)
0 - 4 m	1.5 mm² [AWG 16]
4 - 10 m	2.5 mm² [AWG 14]

#### 4.5.5 Inrush current

At the start of the actuator there is an inrush current to the motor that will last between 75 to 150 milliseconds. See below table to determine the inrush current for the control option being used.

Control Option Inrush Current Level	
Option	Inrush current
LXX, LEX, LXP, CNO, COO	up to 2 × rated current for the actuator model and load in question



If using an AC powered power supply it must be sized to handle the inrush current (batteries typically have no problem delivering the inrush current). Also contacts, switches and relays must be sized appropriately to be able to handle the inrush current.

#### 4.5.6 Regeneration energy and brake resistor installation

When encountering a helping load (pulling load), the motor will send back energy through the system which the power supply must be able to handle. In cases the power supply cannot handle it a brake resistor connected to the brake output must be used. For 24V supply voltage resistance should be between 2.3-3.3 Ohm and for 48V supply voltage resistance should be between 4.7-6.8 Ohm. Use a power resistor that can handle at least 100W.



The regenerated energy will produce heat in the resistor or wherever it is dissipated that the system must be able to handle.

## 4.6 Control options installation and operation

### 4.6.1 General notes



- Avoid placing signal cables along power cables to reduce the risk of interference.
- Avoid using a vehicle earth as the return conductor. Instead use a two wire system to reduce the risk of interference.
- In very sensitive applications or where there is a risk of interference we recommend using shielded signal cables.
- Keep in mind that long cables in combination with small lead cross sections and low voltages may lead to undervoltage and malfunction due to voltage drop.
- Relays or other coil operated devices should have spark protection to avoid interference.
- Never work on the actuator or the wiring with the power switched on!

### 4.6.2 Speed control by adjusting the input voltage



Electrak LL can not be speed controlled by adjusting the input voltage. When using battery or full wave rectified direct current that are within the acceptable voltage limits, the built in Electronic monitoring package will keep the actuator at the correct speed for the load in question. Outside of the limits the actuator will be stopped (section 4.6.3). When using PWM (Pulse Width Modulation) to speed control the actuator, the internal PCB will be permanently damaged and cause malfunction.

### 4.6.3 Basic control functionality

The onboard controls used in Electrak LL can be divided into two groups: those with and those without bus communication. Below is a summary of the features included with these controls. Check the model number on the product label (section 4.1) on your actuator and the ordering key (section 6.2) to understand what type of actuator you have and its features to be able to connect and use it correctly. The safety functions are explained more in detail in section 4.6.4.

Control Options Functionality		
Feature	Non-bus controls	Bus controls
Bus control and communication	no	yes
Low-level switching	yes	yes
Software controlled end-of-stroke protection	yes	yes
Temperature monitoring	yes	yes
Temperature compensation	yes - fixed value	yes - variable value
Voltage monitoring	yes	yes
Current monitoring	yes - fixed value	yes - variable value
End-of-stroke inputs	yes - with option LEX	no
Absolute position feedback	yes - with option LXP	yes
Speed control	no	yes

### 4.6.3 Safety functions

Below a description on how the safety functions works and how they in applicable cases can be reset.

Safety functions		
Feature	Functions	Reset
Speed monitoring	The unit keeps the speed constant.	-
Current monitoring	Shuts down the actuator on overload.	Non bus units: if units stops when extending, reset is done by activating the retract input and vice versa. Bus units: reset is done by disabling the enable bit.
Voltage monitoring	Stops motion when the supply voltage are outside the normal ranges.	When voltage returns to the normal range the actuator can be run again. If the conditions for actuator movement are met when the voltage returns to normal range the actuator immediately will start to move.
Temperature monitoring	Stops motion when the temperature are outside the normal or set (bus units) ranges.	When temperature returns to the normal range the actuator can be run again. If the conditions for actuator movement are met when the voltage returns to normal range the actuator immediately will start to move.
Temperature compensation	Enables operation at low temperatures by increasing the max. allowed current limit by up to $2.25 \times$ the normal limit or to a set value in the case of a bus unit.	-
Software controlled end-of-stroke limits	Protect the actuator and ensure smooth stops.	-
Dynamic braking	Produces quick, repeatable stops with no coasting.	-

## 4.6.4 Control option LEX



To eliminate the risk of the actuator making unplanned moves, for example during emergency stop or when making maintenance work, always turn power off and deactivate control signals.

Power the actuator by connecting lead 2 (red) to + Vdc and lead 1 (black) to - Vdc in the power cable.

If using a brake resistor it should be connected between leads 2 (red) and 3 (brown) in the power cable. Make sure to use the correct type of resistor (section 4.5.6).

To extend the actuator apply voltage between lead 6 (white) and 8 (gray) in the signal cable. To retract the actuator apply voltage between lead 7 (black) and 8 (gray) in the signal cable.

The actuators will stop automatically when reaching the mechanical end of stroke in any directions and motion will only be possible in the opposite direction.

External limit switches can be connected to leads 3 (violet) and 5 (red) and 4 (orange) and 5 (red) in the signal cable in order to stop the motion in either direction before reaching the mechanical ends of stroke. When affected they will stop the actuator and motion will only be possible in the opposite direction.

Control Option Specifications		
Supply voltage limits	[Vdc]	16.8 - 32
Max. actuator current draw	[A]	see product label
Extend / retract input logical high level	[Vdc]	5 - 32
Extend / retract input high current	[mA]	0.35 - 3.15
Extend / retract input logical low level	[Vdc]	< 0.8

+ / - Positive / negative voltage

F Fuse

R Brake resistor (section 4.5.6)

S1 Switch retract

S2 Switch extend

S3 Limit switch stop extend

S4 Limit switch stop retract

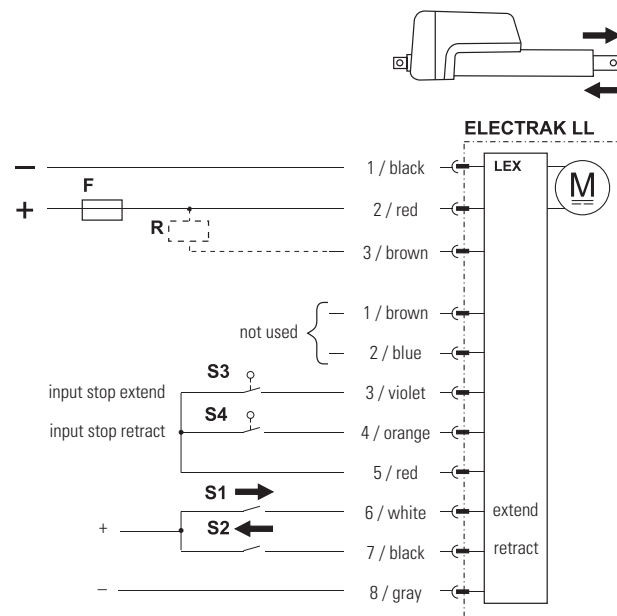

4.6.5 Control option LXX



To eliminate the risk of the actuator making unplanned moves, for example during emergency stop or when making maintenance work, always turn power off and deactivate control signals.

Power the actuator by connecting lead 2 (red) to + Vdc and lead 1 (black) to - Vdc in the power cable.

If using a brake resistor it should be connected between leads 2 (red) and 3 (brown) in the power cable. Make sure to use the correct type of resistor (section 4.5.6).

To extend the actuator apply voltage between lead 6 (white) and 8 (gray) in the signal cable. To retract the actuator apply voltage between lead 7 (black) and 8 (gray) in the signal cable.

The actuators will stop automatically when reaching the mechanical end of stroke in any directions and motion will only be possible in the opposite direction.

Control Option Specifications		
Supply voltage limits	[Vdc]	16.8 - 32.0
LL24		36.0 - 60.0
LL48		
Max. actuator current draw	[A]	see product label
Extend / retract input logical high level	[Vdc]	9 - 60
Extend / retract input high current	[mA]	0.35 - 2.75
Extend / retract input logical low level	[Vdc]	< 1.2

- + / - Positive / negative voltage
- F Fuse
- R Brake resistor (section 4.5.6)
- S1 Switch retract
- S2 Switch extend

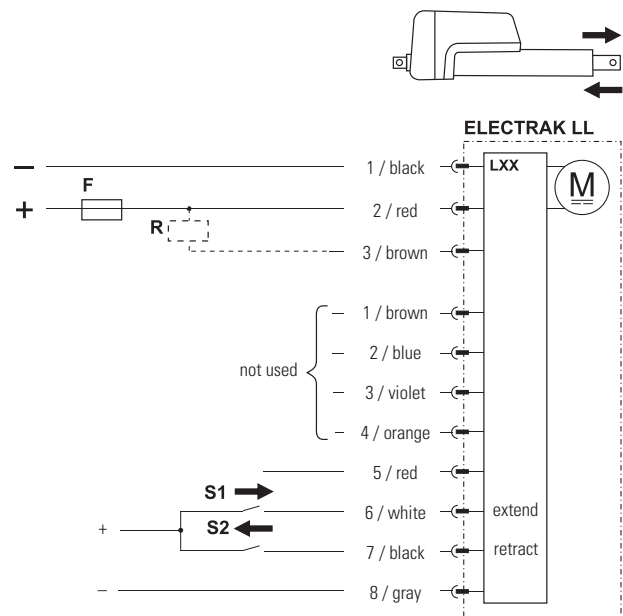

## 4.6.6 Control option LXP



To eliminate the risk of the actuator making unplanned moves, for example during emergency stop or when making maintenance work, always turn power off and deactivate control signals.

Power the actuator by connecting lead 2 (red) to + Vdc and lead 1 (black) to - Vdc in the power cable.

If using a brake resistor it should be connected between leads 2 (red) and 3 (brown) in the power cable. Make sure to use the correct type of resistor (section 4.5.6).

To extend the actuator apply voltage between lead 6 (white) and 8 (gray) in the signal cable. To retract the actuator apply voltage between lead 7 (black) and 8 (gray) in the signal cable.

The actuators will stop automatically when reaching the mechanical end of stroke in any directions and motion will only be possible in the opposite direction.

The supply voltage for the position feedback signal is connected to lead 3 (violet) and 8 (gray) and the output signal is found on lead 4 (orange).

Control Option Specifications		
Supply voltage limits	[Vdc]	
LL24		16.8 - 32.0
LL48		36.0 - 60.0
Max. actuator current draw	[A]	see product label
Extend / retract input logical high level	[Vdc]	9 - 60
Extend / retract input high current	[mA]	0.35 - 2.75
Extend / retract input logical low level	[Vdc]	< 1.2
Position feedback supply voltage	[Vdc]	5 ± 10%
Position feedback output voltage	[Vdc]	0.5 - 4.5
Position feedback linearity	[%]	± 0.25
Position feedback resolution	[mm/V]	ordering stroke length (S) [mm] / 4

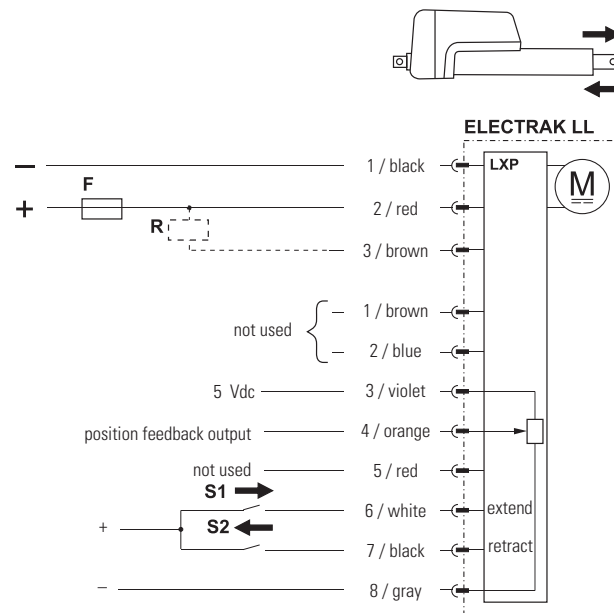

+ / - Positive / negative voltage

F Fuse

R Brake resistor (section 4.5.6)

S1 Switch retract

S2 Switch extend

4.6.7 Control options CNO and COO



This document assumes the user is familiar with the SAE J1939 and CANopen standards. Terminology from the standard is used, but not described in detail. See sections 5 and 6 for information on J1939 and CANopen® operation and communication protocols, respectively.



To eliminate the risk of the actuator making unplanned moves, for example during emergency stop or when making maintenance work, always turn power off and deactivate control signals.

4.6.7.1 General installation data

All motion and protection on the units with a bus option is handled through the CAN messages, including overload protection. Please see sections 5 and 6 for more details on the messages. The CAN high and CAN low wires must also be correctly terminated with termination resistors (section 4.6.7.3).

Inputs on lead 3 (violet), 4 (orange) and 5 (red) can be used as a binary coded decimal (BCD) adder to change the default address of the actuator. This option can be used when multiple bus actuators are located on a single bus. When using the address inputs, lead 8 (gray) must be connected to negative.

Control Option Type CNO and COO	
Command data includes:	
<ul style="list-style-type: none"> <li>• position</li> <li>• speed</li> <li>• current</li> </ul>	
Feedback data includes:	
<ul style="list-style-type: none"> <li>• position</li> <li>• speed</li> <li>• current</li> <li>• other diagnostic information</li> </ul>	

Input Voltage and Current Draw		
Supply voltage limits	[Vdc]	
LL24		16.8 - 32.0
LL48		36.0 - 60.0
Max. actuator current draw	[A]	see product label
Extend / retract input logical high level	[Vdc]	9 - 60
Extend / retract input high current	[mA]	0.35 - 2.75
Extend / retract input logical low level	[Vdc]	< 1.2

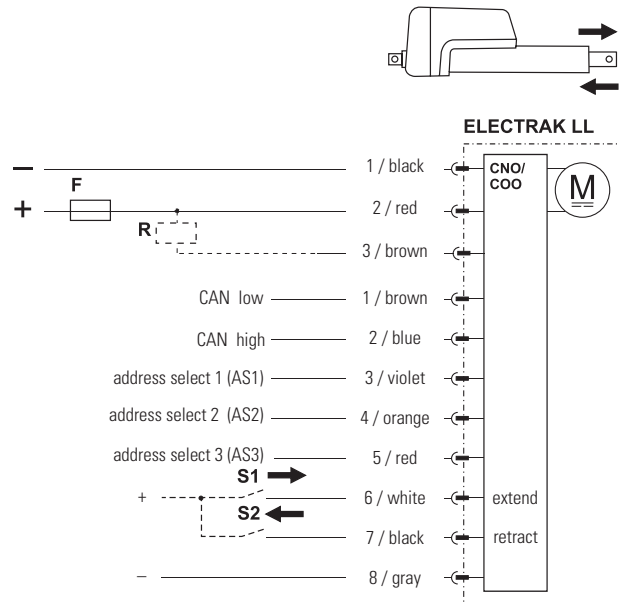

- + / - Positive / negative voltage
- F Fuse
- S1 Manual extend switch/relay (optional)
- S2 Manual retract switch/relay (optional)
- AS1 Address selection switch for binary position 1
- AS2 Address selection switch for binary position 2
- AS3 Address selection switch for binary position 3

4.6.7.2 Manual control

The actuator can be manually forced to extend or retract by using the inputs on pins 6 (white) and 7 (black). When the manual control inputs are used, CAN bus control messages are ignored, but the unit will still provide CAN bus feedback messages. When the inputs are left floating, CAN bus functionality for control messages is restored. When using the manual control extend and retract inputs, pin K must be connected to supply voltage negative.

4.6.7.3 CANopen and SAE J1939 CAN bus installation data

Follow wiring guidelines per ISO-11898 Standard CAN 2.0B. Proper termination resistors (120 Ohm) should be placed between the CAN high and CAN low wires in each end of the of the network, see below. Please refer to section 5 for SAE J1939 communication details, and section 6 for CANopen communication details.

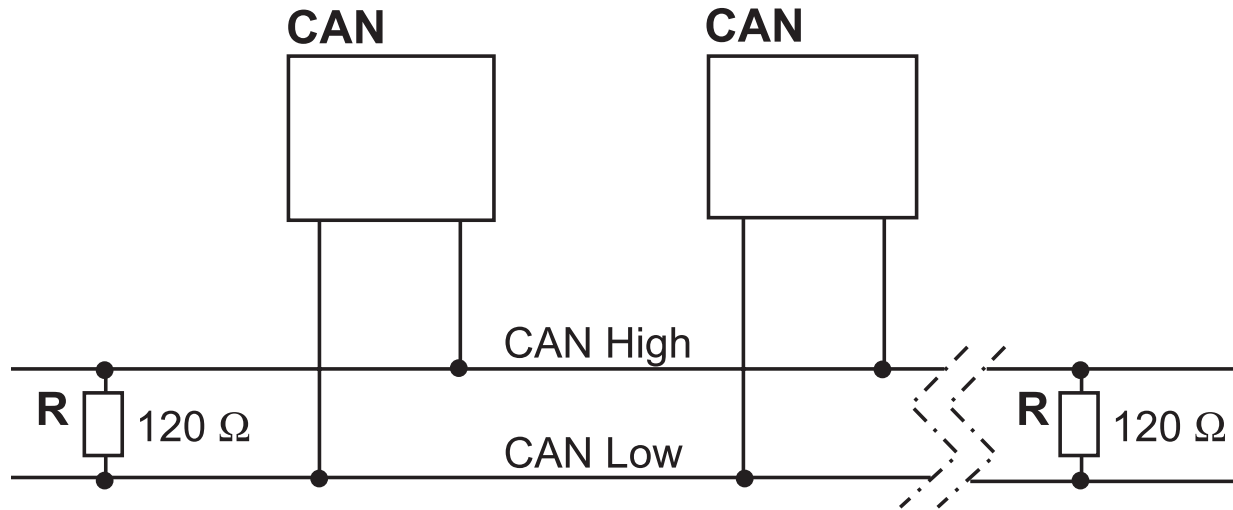

CAN CAN bus device in actuator or other equipment

R Resistor

## 5. SAE J1939 CAN bus information

### 5.1 Introduction to SAE J1939 CAN bus

This document assumes the reader is familiar with the SAE J1939 standard. Terminology from the standard is used, but not described in detail. The default baud rate is 250kbit/s. The Electrak® LL actuator is compliant with the standard SAE J1939 and supports the following Parameter Group Numbers (PGNs) from the standard.

SAE J1939-21 – Data Link Layer

- Proprietary A 61184 (0x00EF00)
- Proprietary A2 126720 (0x01EF00)

SAE J1939-81 – Network Management

- Address Claimed/Cannot Claim 60928 (0x00EE00)
- Commanded Address 65240 (0x00FED8)

### 5.2 SAE J1939 CAN bus communications protocol

#### 5.2.1 SAE J1939 NAME

The Electrak LL has the following defaults for the SAE J1939 NAME. Please refer to the SAE J1939/81 standard for more information on these parameters.

SAE J1939 NAME Defaults	
Arbitrary Address Capable	Yes
Industry Group	0, Global
Vehicle System Instance	0
Vehicle System	0, Non-specific system
Function	255, Not available
ECU Instance	0, First instance
Manufacture Code	547, Thomson Linear LLC
Identity Number	1

#### 5.2.2 Address

The Electrak LL uses a default address value of 19 (0x13). In applications where the default address is not available, there are three additional methods in choosing a new address.

1. The Electrak LL device is arbitrary address capable. If another device with a higher priority NAME contends for the selected address, the actuator will continue to request other addresses until it finds one that it can claim.
2. The Electrak LL device can also use the commanded address PGN to select a specified address. See SAE J1939/81 for more details about address claiming.
3. In some applications, it may be more convenient to select an address through hardware switches. Activate the desired address select input by connecting it to positive and address select common to negative. This allows the user to change the default address using the address select inputs as defined in the table below. Activating individual select pins will create a binary adder to the default address. This method can allow up to 8 individual actuator addresses on a single bus. The below chart shows some examples on how this can be implemented. Note that conflicting messages produce arbitrary execution.

Address Select					
Address select common	Address select 3	Address select 2	Address select 1	Binary adder	Default address
Gnd	0	0	0	0	19 (0x13)
Gnd	0	0	1	1	20 (0x14)
Gnd	0	1	0	2	21 (0x15)
...					
Gnd	1	1	1	7	26 (0x1A)

### 5.2.3 SAE J1939 actuator control message (ACM)

All actuator control parameters are adjustable through the proprietary A message (PGN 61184). The preferred transmission repetition rate is 100 ms (can also be sent as required by the application). Additional message specific information can be found in the table below, all other Proprietary A information can be found in the SAE J1939/21 specification. A unit with the default address will respond to a control message with ID 0x18EF1300.

SAE J1939 Actuator Control Message (ACM)			
Parameter	Resolution/bit	Max/min value	Address [byte.bit]
Target position	0.1 mm	6553.5 mm	0.0 - 1.7
Current limit	0.1 A	6553.5 A	2.0 - 3.7
Target speed	1 mm/s	255 mm/s	4.0 - 4.7
Factory use	-	-	5.0 - 6.7
Control bits	-	-	7.0 - 7.5

#### 5.2.3.1 Target position

The target position for the next actuator motion. The 0.0 mm and full extend stroke values represent 0 to 100% stroke and are only relative to the actual available stroke of the individual unit.  
Resolution: 0.1 mm/bit, 0 offset.

#### 5.2.3.2 Current limit

The current at which the actuator will cease all motion. In the event a force is applied to the actuator that causes the motor current to exceed this settable value for more than 15 ms, the actuator will stop any current motion and activate a dynamic braking effect on the motor. This current limit does not apply during the motor starting phase where in rush current can be significantly higher than normal running. The current is measured at the motor phases (which is not the same as the power source current). Below chart represents the max current values for each configuration, but the actual setting should be determined based on the application. Note that the corresponding load will change with variations in actuator efficiency. Also note that the current limit is intended to protect the actuator and the equipment in case of a hard stop, and should not be used as a means to stop the actuator during normal operation.

Range: 0.0 A to 6.5 A (48 Vdc actuator), 0.0 A to 13.0 A (24 Vdc actuator)

Resolution: 0.1 A/bit, 0 offset

Maximum Current Limit Settings						
Actuator model	LL24B020	LL24B040	LL24B060	LL48B020	LL48B040	LL48B060
Max. setting	15 A	15 A	12 A	7.5 A	7.5 A	6 A

#### 5.2.3.3 Target speed

Controls the target speed of the actuator. See table in section 8.1 for the speed of each actuator model.

Range: 0 to 255 mm/s.

Resolution: 1 mm/s/bit, 0 offset.

#### 5.2.3.4 Control bits

Bit 0 (LSB) – Enable bit: This bit is used to enable motion from the actuator. If it is low (0), no motion will be allowed. This bit can be used to define the next actuator movement message without starting the motor. When movement is required this bit can be changed to high (1) and motion will begin using the values of the other objects contained in the ACM.

### 5.2.4 SAE J1939 actuator feedback message (AFM)

All actuator feedback data can be retrieved through the proprietary A2 message (PGN 126720). This message is transmitted every 100 ms. Additional message-specific information can be found in the table below, and all other Proprietary A2 information can be found in the SAE J1939/21 specification. A unit with the default address will send out the feedback message with ID 0x19EFFF13.

SAE J1939 Actuator Feedback Message (AFM)			
Parameter	Resolution/bit	Max/min value	Address [byte.bit]
Measured position	0.1 mm	6553.5 mm	0.0 - 1.7
Measured current	0.1 A	6553.5 A	2.0 - 3.7
Measured speed	1 mm/s	255 mm/s	4.0 - 4.7
Factory use	-	-	5.0 - 5.7
Motion flags	-	-	6.0 - 6.7
Error flags	-	-	7.0 - 7.5

#### 5.2.4.1 Measured position

The measured position of the actuator. The 0.0 mm and ordered full extend stroke values represent 0 to 100% stroke but the signaled value does not take into account any mechanical tolerances or play in the actuator.

Resolution: 0.1 mm/bit, 0 offset.

Range: 0.0 mm to 450.0 mm

Resolution: 0.1 mm/bit, 0 offset

#### 5.2.4.2 Measured current

The motor current drawn during the active phase of the PWM duty cycle measured between the motor phases (which is not the same as the power source current).

Resolution: 0.1 A/bit, 0 offset

#### 5.2.4.3 Measured speed

The speed measured by the actuator's internal sensors.

Resolution: 1 mm/s/bit, 0 offset.

#### 5.2.4.4 Motion flags

Contains information about the current actuator motion.

Bit 0 (LSB) – Extending: 1 if currently extending, 0 otherwise.

Bit 1 – Retracting: 1 if currently retracting, 0 otherwise.

Bit2 – Saturated: 1 if the unit is moving at the maximum speed allowed by the input voltage and load. 0 otherwise.

#### 5.2.4.5 Error flags

Contains information about actuator errors.

Bit 0 (LSB) - Parameter error: This flag is used to inform the user that one of the object values in the ACM is outside the allowed ranges of the specific model. To prevent damage to the actuator, motion is not allowed after this flag is set.

Bit 1 – Current overload: This flag is used to inform the user that the last motion the actuator attempted caused an overload condition. This occurs when the actuator determines the current set in the Current Limit object from the ACM is exceeded for a consecutive 15 ms. When this flag is set by the actuator the user must reset the Motion Enable bit in the ACM before attempting additional motion from the actuator.

Bit 2 – Voltage error: This flag is used to inform the user that the operational voltage is outside of allowable running parameters. Any motion already in progress will continue for 10 seconds, but additional movement request will not be allowed until the operational voltage returns within the normal operating range.

Bit 3- Temperature error: This flag is used to inform the user that the operational temperature is outside of allowable running parameters. Any motion already in progress will continue for 10 seconds, but additional movement request will not be allowed until the operational temperature returns within the normal operating range.

Bit 4 – Backdrive detected: This flag is used to inform the user that the actuator has determined positional movement in the extension tube that was not commanded from the user. This can be caused from excessive static load or vibration being applied to the actuator.

Bit 5 – Message timeout: this flag is used to inform the user that no control message has been received within the time specified in the timeout time settings parameter. The default value is 5000 ms.

Bit 6 – Fatal error: This flag is used to inform the user that the actuator was unable to detect any motion while trying to run the motor. When this flag is set by the actuator the user must reset the Motion Enable bit in the RPDO before attempting additional motion from the actuator. Repeated activation of this flag indicates problems with the actuator, and it is recommended to contact the factory for additional support.

Bit 7(MSB) - Memory error: This flag is used to inform the user that the internal memory of the actuator is corrupted.

## 6. CANopen® information

### 6.1 Introduction to CANopen

#### 6.1.1 CANopen standard

This document assumes the reader is familiar with the CiA 301 specification released by CAN in Automation. Terminology from the standard is used, but not described in detail. The Electrak® LL actuator is compliant with the standard. The default baud rate is 500 kbit/s, and it will only support the standard CAN frame with 11-bit identifier field.

#### 6.1.2 EDS file

Thomson provides an electronic data sheet file (EDS) to integrate the Electrak LL into a specific CANopen network. The EDS file can be downloaded at: [www.thomsonlinear.com/en/support/docs-linear-actuators#literature](http://www.thomsonlinear.com/en/support/docs-linear-actuators#literature)

#### 6.1.3 Node ID

The Electrak LL uses a default node ID of 19 (0x13). In applications where the default address is not available, it is possible to select an address through hardware switches. Activate the desired address select input by connecting it to positive and address select common to negative. This allows the user to change the default address using the address select inputs as defined in the table found below. Activating individual select pins will create a binary adder to the default address. This method can allow up to 8 individual actuator addresses on a single bus. The below chart shows some examples on how this can be implemented.

Address Select					
Address select common	Address select 3	Address select 2	Address select 1	Binary adder	Default address
Gnd	0	0	0	0	19 (0x13)
Gnd	0	0	1	1	20 (0x14)
Gnd	0	1	0	2	21 (0x15)
...					
Gnd	1	1	1	7	26 (0x1A)

#### 6.1.4 NMT State

The Electrak LL supports the CANopen network management (NMT) slave state machine. It needs to be put in the operational state before operating properly.

Example:

Sending a CAN message with id 0x0, containing the data 0x01 0x00 will put all connected actuators in the operational state. Sending a CAN message with id 0x0, containing the data 0x01 0x13 will put an actuator with the default Node ID in the operational state.

## 6.2 Actuator control

### 6.2.1 Control PDO properties

Operational control of the actuator is achieved by sending the statically mapped RPDO with COB-ID \$200 + Node ID. It will have the following layout:

Byte 0	Byte 1	Byte 2	Byte 3	Byte 4	Byte 5	Byte 6	Byte 7
Target Position		Current Limit		Target Speed	Not used	Not used	Control Bits

### 6.2.2 Control PDO entries

The Object Dictionary entries mapped to the RPDO are:

Index	0x2100
Name	Target Position
Object Type	VAR
Data Type	UNSIGNED16
Description	The target position for the next actuator motion. The 0.0 mm and full extend stroke values represent 0 to 100% stroke and are only relative to the actual available stroke of the individual unit. Resolution: 0.1 mm/bit, 0 offset.

Index	0x2101
Name	Current Limit
Object Type	VAR
Data Type	UNSIGNED16
Description	The current at which the actuator will cease all motion. In the event a force is applied to the actuator that causes the motor current to exceed this settable value for more than 15 ms, the actuator will stop any current motion and activate a dynamic braking effect on the motor. This current limit does not apply during the motor starting phase where in rush current can be significantly higher than normal running. The current is measured at the motor phases (which is not the same as the power source current). Below chart shows the recommended current limit values for each configuration. Note that the corresponding load will change with variations in actuator efficiency. Also note that the current limit is intended to protect the actuator and the equipment in case of a hard stop, and should not be used as a means to stop the actuator during normal operation.  Range: 0.0 A to 6.5 A (48 Vdc actuator), 0.0 A to 13.0 A (24 Vdc actuator) Resolution: 0.1 A/bit, 0 offset

Maximum Current Limit Settings						
Actuator model	LL24B020	LL24B040	LL24B060	LL48B020	LL48B040	LL48B060
Max. setting	15 A	15 A	12 A	7.5 A	7.5 A	6 A

Index	0x2102
Name	Target Speed
Object Type	VAR
Data Type	UNSIGNED8
Description	Controls the target speed of the actuator. See table in section 8.1 for the speed of each actuator model. Range: 0 to 255 mm/s. Resolution: 1 mm/s/bit, 0 offset.

Index	0x2105
Name	Control Bits
Object Type	VAR
Data Type	UNSIGNED8
Description	Bit 0 (LSB) – Enable bit: This bit is used to enable motion from the actuator. If it is low (0), no motion will be allowed. This bit can be used to define the next actuator movement message without starting the motor. When movement is required this bit can be changed to high (1) and motion will begin using the values of the other objects contained in the RPDO.

### 6.2.3 Control PDO example

Sending a CAN message with ID 0x213 containing the data 0xE8 0x03 0x64 0x00 0x1E 0x00 0x00 0x01 will make an actuator move to position 100 mm, at 30 mm/s, with the current limit set to 10.0 A. The example will work on an actuator with the default Node ID if it is in the operational NMT state.

### 6.3 Actuator feedback

#### 6.3.1 Feedback PDO properties

Operational feedback of the actuator is achieved by receiving the statically mapped TPDO with COB-ID \$180 + Node ID. It will have the following layout:

Byte 0	Byte 1	Byte 2	Byte 3	Byte 4	Byte 5	Byte 6	Byte 7
Measured Position		Measured Current		Measured Speed	Not used	Motion Flags	Error Flags

#### 6.3.2 Feedback PDO entries

The Object Dictionary entries mapped to the TPDO are:

Index	0x2200
Name	Measured Position
Object Type	VAR
Data Type	UNSIGNED16
Description	The measured position of the actuator. The 0.0 mm and ordered full extend stroke values represent 0 to 100% stroke but the signaled value does not take in to account any mechanical tolerances or play in the actuator. Resolution: 0.1 mm/bit, 0 offset.

Index	0x2201
Name	Measured Current
Object Type	VAR
Data Type	UNSIGNED16
Description	The motor current drawn during the active phase of the PWM duty cycle, which is measured between the motor phases (which is not the same as the power source current). Resolution: 0.1 A/bit, 0 offset

Index	0x2202
Name	Measured Speed
Object Type	VAR
Data Type	UNSIGNED8
Description	The speed measured by the actuator's internal sensors. Resolution: 1 mm/s/bit, 0 offset.

#### 6.3.3 Motion flags

Index	0x2204
Name	Motion Flags
Object Type	VAR
Data Type	UNSIGNED8
Description	Contains information about the current actuator motion. Bit 0 (LSB) – Extending: 1 if currently extending, 0 otherwise. Bit 1 – Retracting: 1 if currently retracting, 0 otherwise. Bit 2 – Saturated: 1 if the unit is moving at the maxi. speed allowed by the input voltage and load. 0 otherwise.

## 6.3.4 Error flags

Index	0x2205
Name	Error Flags
Object Type	VAR
Data Type	UNSIGNED8
Description	<p>Contains information about actuator errors.</p> <p>Bit 0 (LSB) – Parameter Error: This flag is used to inform the user that one of the object values in the RPDO is outside the allowed ranges the specific model will allow. To prevent damage to the actuator motion is not allowed after this flag is set.</p> <p>Bit 1 – Current Overload: This flag is used to inform the user that the last motion the actuator attempted caused an overload condition. This occurs when the actuator determines the current set in the Current Limit object from the RPDO is exceeded for a consecutive 15 ms. When this flag is set by the actuator the user must reset the Motion Enable bit in the RPDO before attempting additional motion from the actuator.</p> <p>Bit 2 – Voltage Error: This flag is used to inform the user that the operational voltage is outside of allowable running parameters. Any motion already in progress will continue for 10 seconds, but additional movement request will not be allowed until the operational voltage returns within the normal operating range.</p> <p>Bit 3 – Temperature Error: This flag is used to inform that the operational temperature is outside of allowable running parameters. Any motion already in progress will continue for 10 seconds, but additional movement request will not be allowed until the operational temperature returns within the normal operating range.</p> <p>Bit 4 – Backdrive Detected: This flag is used to inform the user that the actuator has determined positional movement in the extension tube that was not commanded from the user. This can be caused from excessive static load or vibration being applied to the actuator.</p> <p>Bit 5 – Message Timeout: This flag is used to inform the user that no RPDO has been received within the time specified in the PDO timeout time object (0x2005). When this flag is set by the actuator the user must reset the Motion Enable bit in the RPDO before attempting additional motion from the actuator. The default value is 5000 ms.</p> <p>Bit 6 – Fatal Error: This flag is used to inform the user that the actuator was unable to detect any motion while trying to run the motor. When this flag is set by the actuator the user must reset the Motion Enable bit in the RPDO before attempting additional motion from the actuator. Repeated activation of this flag indicates problems with the actuator, and it is recommended to contact the factory for additional support.</p> <p>Bit 7(MSB)- Memory Error: This flag is used to inform that the internal memory of the actuator is corrupted.</p>

## 7. Troubleshooting

### 7.1 Troubleshooting

Troubleshooting list		
Issue	Problem	Solution
Actuator does not move, makes no sound.	Actuator is not receiving proper input voltage.	Ensure the actuator is being supplied with proper rated input voltage.
Actuator makes buzzing sound, does not move.	Actuator does not have enough power and is stalled.	Ensure your power supply can provide enough current to move the rated load.
The actuator, when powered, is causing my fuse to blow.	Fuse is not rated for current draw of the actuator.	Make sure that the fuse is rated for the in-rush current of the actuator, which is typically 1.5 times the rated current draw of the actuator at full load. Slow-blow fuses are also recommended.
Actuator is sending a "fatal error" message.	The actuator has encountered an uncommanded change in the stroke feedback device (potentiometer).	The actuator will need to be analyzed as an RMA (Return Material Authorization) at the manufacturing facility.
My actuator is not responding to any of the messages I send.	The actuator may have fallen asleep.	The sleep functionality of Electrak LL will engage after 5 seconds of bus inactivity. Send messages to the actuator every 100 ms - 2 s to avoid this from happening. If it has already happened, a "safe state" message will first have to be sent to "wake up" the actuator before it can interpret any other messages.
I am getting an erroneous Overload Flag with no load or current draw on my CNO actuator. How do I fix this?	The actuator control message PGN was set up incorrectly.	<p>"The proper command message should be 18EF1300, where 0x13 is the address of the actuator (default). Keep in mind that if the customer changes the address of the actuator with the physical addressing leads, then the command message will change as well. The address of the CAN controller should be set as something different than the actuator to prevent errors.</p> <p>If an ELS error (C2 on the feedback message) is encountered and the PGN is addressed correctly, simply reset the bus by sending a command message with the enable bit off, then another with it on."</p>

## 8. Technical specifications

### 8.1 Technical data

Technical Specification		ELECTRAK LL
Input voltages	[Vdc]	24, 48
Input voltage tolerance	[Vdc]	
LL24 (24 Vdc input voltage)		16.8 - 32.0
LL48 (48 Vdc input voltage)		36.0 - 60.0
Stroke length	[mm]	see product label
Static load at fully retracted (Fx), maximum	[kN (lbs)]	
LLxx-B020		5 (1124)
LLxx-B040		10 (2248)
LLxx-B060		15 (3372)
Dynamic load (Fx), maximum	[N]	see product label
Speed <sup>(1)</sup>	[mm/s (inch/s)]	
LLxx-B020		54 (2.13)
LLxx-B040		30 (1.18)
LLxx-B060		15 (0.59)
Current draw @ rated max. load	[A]	see product label
Weight <sup>(2)</sup>	[kg]	(stroke [mm] × 0.007) + 6.1
End play, maximum	[mm (in)]	1.2 (0.047)
Operating temperature limits, standard units	[°C (°F)]	- 40 to + 85 (- 40 to + 185)
Full load duty cycle @ 25 °C	[%]	see product label
Restraining torque	[Nm (lbf-in)]	0 (internally restrained)
Motor cable lead cross section	[mm <sup>2</sup> (AWG)]	1.5 (16)
Signal cable lead cross section	[mm <sup>2</sup> (AWG)]	0.5 (20)
Cable length	[mm (in)]	0.3 (11.8)
Protection class - static		IP66 / IP69K
Protection class - dynamic		IP66
Safety features		
static load holding brake		yes
internal end-of-stroke limit switches		yes
overload protection		yes
temperature monitoring		yes
temperature compensation		yes
voltage monitoring		yes
Compliances <sup>(3)</sup>		CE, RoHS, EN 50155, EN 60077, EN 45545

(1) Speed is constant regardless of load unless a unit with bus control is being used that are speed controlled over the bus

(2) Conversion factor for kilogram to pound: 1 kg = 2.204623 lbs

(3) Only the 24 Vdc versions complies to EN 50155, EN 60077 and EN 45545.

8.2 Ordering key

Ordering Key									
Position	1	2	3	4	5	6	7	8	9
Example	<b>LL24</b>	<b>B040-</b>	<b>0300</b>	<b>LEX</b>	<b>1</b>	<b>M</b>	<b>M</b>	<b>S</b>	<b>D</b>
<p>1. Actuator type and supply voltage                      LL24 = Electrak LL, 24 Vdc                      LL48 = Electrak LL, 48 Vdc</p> <p>2. Screw type, dynamic load capacity                      B020- = ball screw, 2.0 kN (450 lbs)                      B040- = ball screw, 4.0 kN (899 lbs)                      B060- = ball screw, 6.0 kN (1388 lbs)</p> <p>3. Ordering stroke length <sup>(1)</sup>                      0100 = 100 mm                      0150 = 150 mm                      0200 = 200 mm                      0250 = 250 mm                      0300 = 300 mm                      0350 = 350 mm                      0400 = 400 mm                      0450 = 450 mm</p> <p>4. Control option                      LEX = Electrak Monitoring Package + low-level signal motor switching + external end-off-stroke limit switch inputs <sup>(2)</sup>                      LXX = Electrak Monitoring Package + low-level signal motor switching                      LXP = LXX + absolute position feedback output <sup>(3)</sup>                      CNO = SAE J1939 CAN bus + open-loop speed control <sup>(3)</sup>                      COO = CANopen CAN bus + open-loop speed control <sup>(3)</sup></p> <p>5. Cable option                      A = 0.3 m long railway approved cables with flying leads (number coded leads)                      1 = 0.3 m long halogen-free cables with flying leads (color coded leads)                      2 = 1.5 m long halogen-free cables with flying leads (color coded leads)                      3 = 5.0 m long halogen-free cables with flying leads (color coded leads)</p>					<p>6. Rear adapter option                      M = cross hole for 12 mm pin                      E = cross hole for ½ inch pin                      N = forked cross hole for 12 mm pin                      F = forked cross hole for ½ inch pin                      S = stainless cross hole for 12 mm pin                      T = stainless forked cross hole for 12 mm pin</p> <p>7. Front adapter option                      M = cross hole for 12 mm pin                      E = cross hole for ½ inch pin                      N = forked cross hole for 12 mm pin                      F = forked cross hole for ½ inch pin                      P = metric female thread M12 × 1.75                      G = inch female thread 1/2-20 UNF-2B                      S = stainless cross hole for 12 mm pin                      Q = stainless metric male thread M16 × 2                      R = stainless metric female thread M16 × 2                      T = stainless forked cross hole for 12 mm pin</p> <p>8. Adapter orientation                      S = standard                      M = 90 ° turned</p> <p>9. Connector option                      D = flying leads</p> <p><small>(1) Other stroke lengths available upon request. Please contact customer support.                      (2) Only available with 24 Vdc input voltage.                      (3) Available for both 24 and 48 Vdc input voltages.</small></p>				

- Page intentionally left blank -

Contact us or any of our 2000+ global distribution partners by scanning the code below  
or visiting [www.thomsonlinear.com/contact](http://www.thomsonlinear.com/contact)



**RegalRexnord™**

[www.regalrexnord.com](http://www.regalrexnord.com)

[www.thomsonlinear.com](http://www.thomsonlinear.com)

Electrak\_LL\_Installation\_Operation\_MNEN-0007-10 | 20260122KB  
Specifications are subject to change without notice. It is the responsibility of the product user to determine the suitability of this product for a specific application. All trademarks property of their respective owners. ©2026 Thomson Industries, Inc. | 2400 Curtiss Street, Downers Grove, IL 60515 USA

**THOMSON®**